

This camera manual library is for reference and historical purposes, all rights reserved.

This page is copyright by mike@butkus.org M. Butkus, N.J.

**This page may not be sold or distributed without the expressed
permission of the producer**

I have no connection with any camera company

If you find this manual useful, how about a donation of \$3 to: M. Butkus, 29 Lake Ave., High Bridge, NJ 08829-1701 and send your E-mail address too so I can thank you. Most other places would charge you \$7.50 for a electronic copy or \$18.00 for a hard to read Xerox copy. These donations allow me to continue to buy new manuals and maintain these pages. It'll make you feel better, won't it?

If you use Pay Pal, use the link below. Use the above address for a check, M.O. or cash. Use the E-mail of butkusmi@ptd.net for PayPal.



[back to my "Orphancameras" manuals /flash and light meter site](#)

Only one "donation" needed per manual, not per multiple section of a manual !

The large manuals are split only for easy download size.

www.orphancamera.com

Wide-angle and Tele- Rolleiflex

Series III

in practical use



Rollei

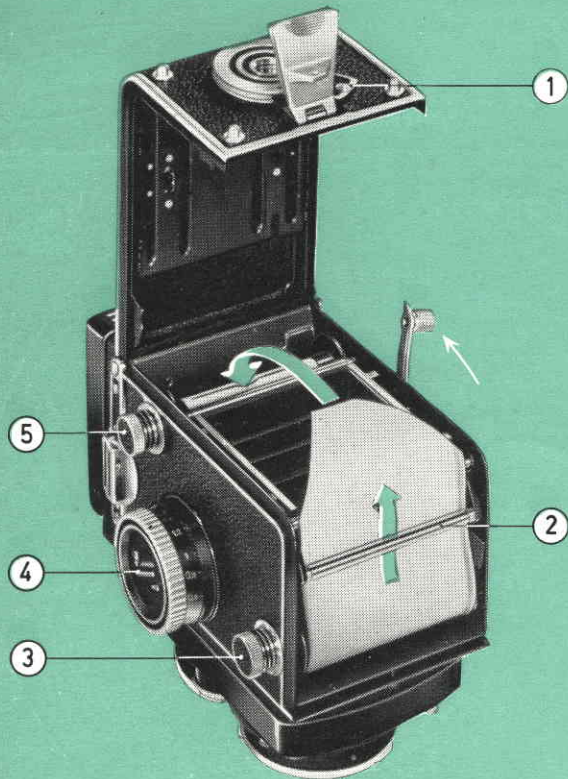

Loading the Camera:

Unlatch the camera back ① and swing open. Pull out the knob ③. Insert the roll of film from the right. Pull the paper leader under the roller ②, push into the slot of the empty spool, and tighten with half a turn of the crank. Close the camera back.

Turn the crank clockwise until it locks, then turn back till it locks (as when advancing the film subsequently). The film counter now indicates exposure No. 1.

Setting the Film Indicator:

Turn the key ④ clockwise (to set the ASA or DIN rating) and then anti-clockwise (to set the film type).

Focusing:

Push up the focusing hood at the rear. Press the key ⑥ to swing up the magnifier. Turn the knob ⑦ to focus the finder image in the hood for maximum sharpness.

Summary

Setting the Exposure:

To couple the aperture-speed controls engage the exposure value by aligning the slot of the button (8) with the marks on the wheel (9). Press the button (8) and set the scale of the wheel (11) to the required (measured) exposure value. To select the aperture-speed combination in the window (12) turn the wheel (11) or (9).

To disengage the aperture-speed coupling, uncouple the exposure value (line up the slot of the button (8) at right angles to the marks), then turn the wheels for the aperture (9) and for the exposure time (10) individually.

Releasing:

Swing the locking lever (10) downwards (↓) and press the release button. The shutter is automatically tensioned on advancing the film.

Changing Films:

After the twelfth exposure wind up the end of the roll with four turns of the crank. Open the camera, pull out the knob (5), and remove the film.

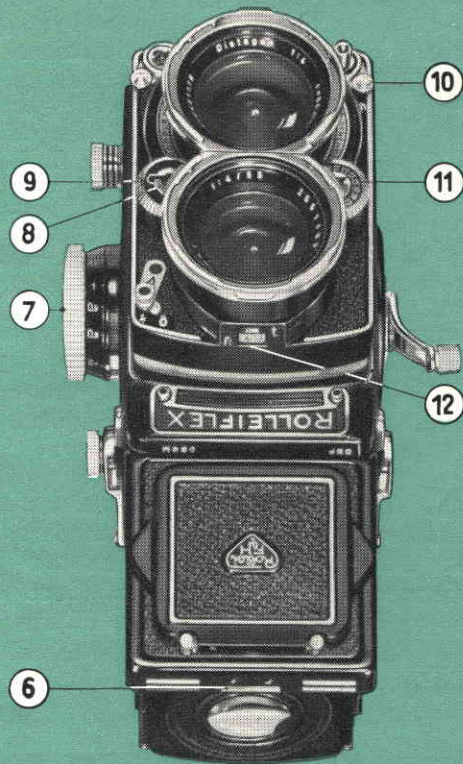

The First Two Pages

have shown you already the basic points of the Rollei. You can start shooting straight away.

In the following sections you will find a detailed description of the Rollei in practical use. The illustrations show the Wide-angle Rolleiflex. The Tele-Rolleiflex is handled in the same way.

The 55 mm. Distagon f/4 (angle of view 71°) and the 135 mm. Sonnar f/4 (angle of view 33°), both Carl Zeiss lenses, characterise the specific field of application of each camera.

With their fixed lenses, common features and similar operation the two models complement each other. They thus provide immediate interchange of focal lengths and make the best use of the constant readiness for shooting and of the high performance of each Rollei model.

ROLLEI-WERKE FRANKE & HEIDECKE

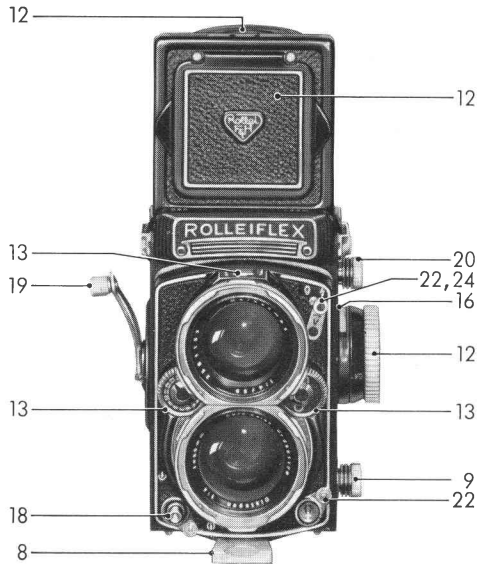

Quick Guide to Important Points

	Page		Page
Two-page Summary	2 – 3	Care of the Camera	21
The Eveready Case	6	Flash Shots	22 – 23
The Lens Cap	7	The Self-timer	24
The Carrying Strap	7	Tripods	24
Loading the Camera	8 – 10	Double Exposures	25
Optically Flat Glass Plate	10 – 11	Time Exposures	25
Focusing	12	The Exposure Meter	26 – 27
Setting the Exposure	13	Correct Exposure:	
Setting the Shutter Speed	14 – 15	Reflected and Incident Light	
Selecting the Depth of Field	16 – 17	Readings	28 – 29
Releasing	18	The Rolleikin	30
The Film Transport	19	Changing the Magnifier	31
Tensioning the Shutter	19	Changing the Camera Back	31
Unloading the Camera	20	The Practical Accessories	32 – 34

References to "left, right, front, rear, top, bottom" apply to the camera held in shooting position. Thus the focusing knob is on the left, the transport crank on the right, and so on.

Eveready Case



Opening the case: Raise the top at the back ① and fold forward and down. Before closing the case set the camera to ∞ (infinity).

Removing the camera: Swing down the locking levers ② at the two sides of the strap holder.

Raise the crank.

Spread the sides of the case apart and lift out the camera from the front. When inserting the camera first guide the crank into the case. Lock the sides to the camera with the lever ②.

Detaching the front (if required): Swing down the clip ③. To attach the front, hook it into the hinge and close the case.

The leather loop and press button studs at the left side of the eveready case take and hold the protective leather cap for the exposure meter. To open the case, release only the lower press stud of the protective cap.

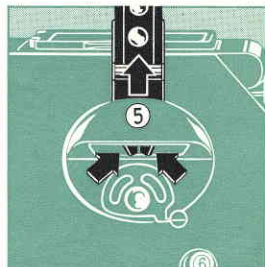
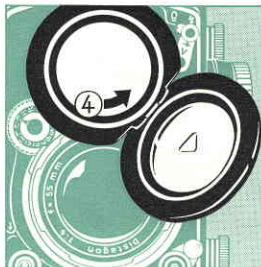
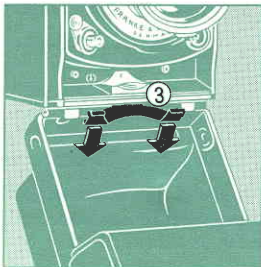
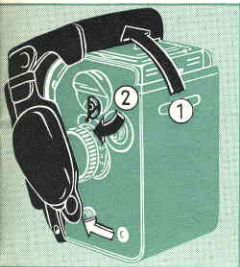

Lens Cap

Swing up the cap and turn anti-clockwise to remove it from the bayonet mount ④. Attach accordingly at the same angle.

Carrying Strap

Push the prongs of the strap into the strap holder (of the camera or of the eveready case) and let them engage. To remove the strap, push the prongs together ⑤.

Loading the Camera

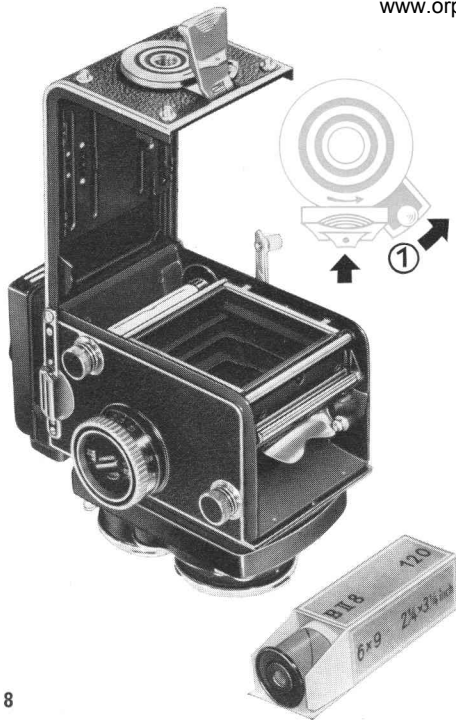

The Film:

Use size 120 roll film for 12 exposures $2\frac{1}{4} \times 2\frac{1}{4}$ inches (6 x 6 cm.). 35 mm. miniature film can also be used with the Rolleikin set, yielding up to 36 exposures 24×36 mm.

Opening the Camera:

Swing aside the locking lever ①, unlatch the back and fold open.

Adjusting the Pressure Plate:

Press the plate against the camera back and push it to engage in the required position ②. Then let it spring forward again.

Bottom position:

$2\frac{1}{4} \times 2\frac{1}{4}$ inch (6 x 6 cm.) pictures on roll film with flat glass plate (→ page 10)

Centre position:

$2\frac{1}{4} \times 2\frac{1}{4}$ inch (6 x 6 cm.) pictures on roll film without flat glass plate

Top position:

24×36 mm. pictures on miniature. film (flat glass plate not required).

Threading the film: Pull out the film knob ③ at the lower spool chamber and insert the full spool – right hand side first. Let the film knob spring back fully.

Remove the adhesive paper seal.

Pull the beginning of the backing paper – with the colored side outwards – between the rollers of the film feeder mechanism ④ and push it fully into the long slit ⑤ of the empty spool.

Adjust the position of the spool by turning the crank. Tighten the backing paper on the take-up spool with half a turn of the crank; at the same time press against the full spool with your thumb.

Closing the camera: Close the camera back, swing the latch over the retaining pin, and lock ⑥.

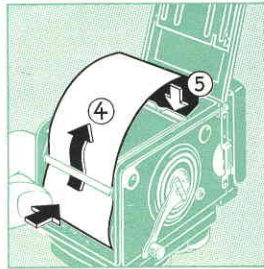
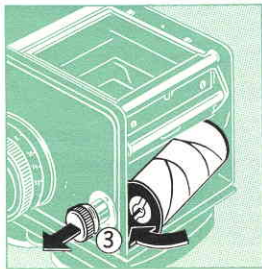
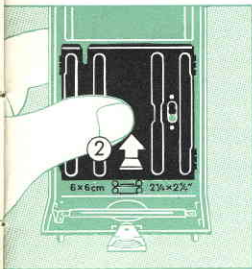



Setting the film indicator: Turn the key ① clockwise to set the film speed in ASA or DIN, and anti-clockwise to set the type of film in use.

Replacing the film indicator by the exposure meter: → page 26.

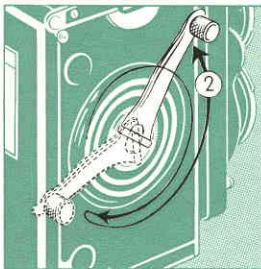

Advancing the film to No. 1: Swing the crank round and round, past a resistance (at which the counter mechanism engages) until the crank locks. Then swing back in the opposite direction until it stops again ②. The crank is now locked in its original position. The film counter indicates No. 1, the shutter is tensioned, and the film is in position for the first exposure.

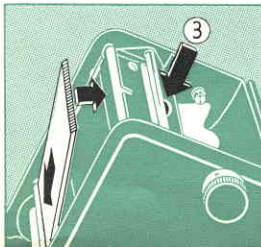

The 2¼ x 2¼" Flat Glass

provides a continuous film track against the emulsion side of the film. This holds the film completely flat over its whole area like a plate and ensures maximum precision in the positioning of the film plane. The use of the flat glass plate is particularly advisable for occasions where utmost definition is essential.

After inserting the flat glass plate the film is loaded in the usual way. A mechanical catch brings the pressure plate into action only when the point of attachment of the film to the backing paper has passed through and the camera is ready for the first exposure.

Inserting: Tilt the open camera forward. Slide the glass with the bevelled edge under the upper ledge of the film track, let it drop into position, and lock by pressing and releasing the catch ③.

Removing the flat glass: Place the camera upside-down, press the catch ③ to release the plate, and let it drop out into your hand. When not in use, store the flat glass in the special inside compartment of the eveready case.

Cleaning: The use of the flat glass demands great care and cleanliness. Remove all traces of dust and finger marks from both sides and hold the glass only by the edges when inserting. Minor wiping traces on the film side of the glass will not affect the picture quality.

Comparison Values Between DIN and ASA Speeds

DIN	ASA	DIN	ASA
10	8	25	250
11	10	26	320
12	12	27	400
13	16	28	500
14	20	29	650
15	25	30	800
16	32	31	1000
17	40	32	1300
18	50	33	1600
19	64	34	2000
20	80	35	2500
21	100	36	3200
22	125	37	4000
23	160	38	5000
24	200	39	6300

Focusing

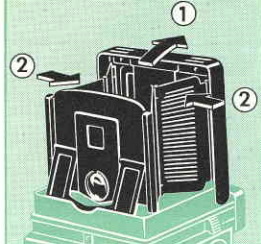

To open the hood: Lift up the top from the back ①. To close, push the sides inwards to fold them up ②.

To raise the Magnifier (Wide-angle Rolleiflex): Press the key ③ to let the magnifier spring up.

To raise the Magnifier (Tele-Rolleiflex): Slightly push the flap of the focusing hood inwards. The best way is to hold the upper edge of the hood with two fingers and press the fingertip against the top of the flap ⑥.

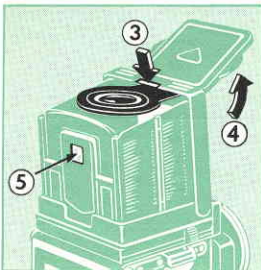

Hold the magnifier close to the eye.

To close the Magnifier: Fold down the magnifier support.

To focus: Turn the focusing knob until the image appears sharpest on the screen or until the split outlines join up in the measuring wedge in the centre of the finder.

To use the eye-level optical finder (Wide-angle Rolleiflex): Open the magnifier ③ and the cover ④. Sight the subject through the finder eyepiece ⑤.

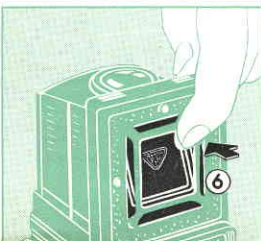

To use the frame finder (Tele-Rolleiflex): Fully push in the flap ⑥. The magnifier underneath the eye-level finder eyepiece shows the sharpness and focus in the centre of the focusing screen. – To close the frame finder: Slightly press in both sides of the focusing hood ②.

Setting the Exposure

With Exposure Value Engaged



Locking the cross-coupling: Press the button on the aperture wheel and engage the slot in line with the index marks. That couples the aperture and shutter speed controls so that any combination yields the same exposure.

Setting the exposure value: Press the button and set the shutter speed wheel to the required full or intermediate exposure value. (If the required exposure value cannot be reached in this way, release the button, turn back the shutter speed wheel, and repeat the process.)

Selecting the aperture-speed combination: Set the required combination in the peep window by turning the coupled wheels.



With the Controls Uncoupled



Uncoupling the controls: Press the button in the centre of the aperture wheel and set the slot at right angles to the index marks. Aperture and shutter speed can now be set independently.

Setting the speed and aperture: Operate the two wheels separately.

On stopping down the aperture, the light passing through the lens is reduced to one-half at each successive stop; the required exposure time must therefore be doubled.

The aperture can also be set to any intermediate value.



Important: Always let the shutter speed figure engage exactly in the centre of the window.

Selecting the Shutter Speed



Automatic, shutter timed exposures							Time exposures by hand			
1/500	1/250	1/125	1/60	1/30	1/15	1/8	1/4	1/2	1	B
quick movements			moderate		scenes without movement (tripod!)					

The red figures indicate automatically timed instantaneous exposures in fractions of a second. Intermediate values between those engaged by the control can not be used, so:

Always set the shutter speed exactly in the centre of the window.

The green letter **B** is for time exposures of any desired length (→ page 18).

After setting the exposure value according to the subject brightness and film speed, the choice of aperture-speed combinations depends on the subject movement or the required depth of field:

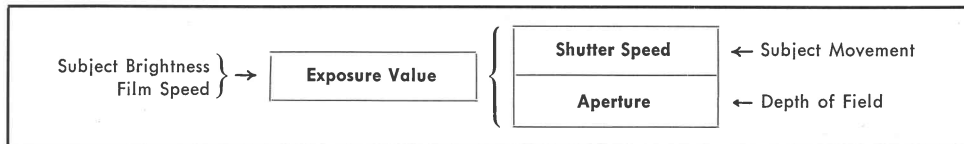

500



250

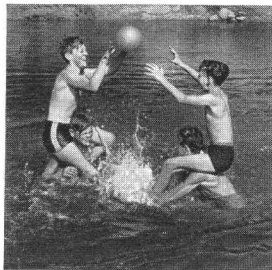

125



What Shutter Speed?

Selecting a sufficiently short shutter speed is an important factor in getting a sharp picture.

First rule: in hand-held shots, use fast speeds to avoid camera movement. The longest permissible shutter speed is 1/30 sec. Safer and most widely used: 1/60 and 1/125 sec.

Second rule: In scenes involving motion, the faster the objects move, the shorter the exposure has to be, to prevent a blurred picture.

As a guide: sport scenes 1/500, running children 1/250, quick marching pedestrians 1/125, people walking leisurely 1/60 or—from some distance—1/30. To eliminate the possibility of blurred scenes, remember this general rule: the danger of subject movement is greatly reduced by increasing the taking distance and shooting as nearly in line with the direction of motion as possible, in other words, rather from the front than from the side.

What About Depth-of-Field?

A sharp focusing screen image indicates that the camera is focused correctly on the main subject.

But both before and behind the plane of sharp focus there is always a sufficiently sharp zone. The range of this "depth-of-field" is shown by a white band on the focusing knob: the length of the white band indicates on the distance scale the depth-of-field available.

The bands of the depth of field indicator are coupled with the aperture control. With any given exposure value the shutter speed and depth of field can thus be selected in direct combination without reference to the aperture. The faster the film in the camera, the easier it becomes to combine a high shutter speed with great depth of field.

The zone of definition does not break off abruptly, but gradually changes to unsharpness. Therefore it is difficult to define the exact limits of the depth-of-field. Maximum definition always prevails at the focusing distance.

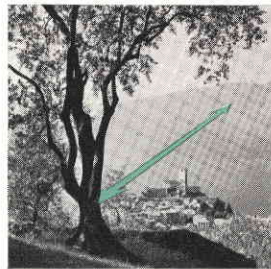
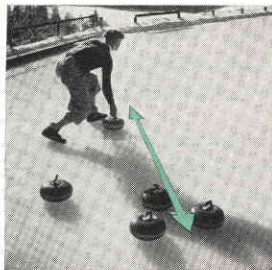
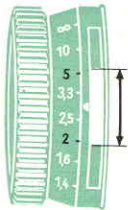

When Does One Need Depth-of-Field?

Extended depth-of-field becomes very helpful when taking surprise snapshots, sport scenes with constantly changing subject distance and subjects with extended depth.

Snapshots with the camera pre-focused to the anticipated distance: work with extended depth-of-field to compensate for changes in the focusing distance.

Landscapes with foreground: to extend the depth-of-field as far as possible into the foreground, do not set the camera to ∞ , but turn the focusing knob until the ∞ mark is opposite the end of the indicator band.

Subjects with great depth: focus separately on the nearest and farthest point bracketing the subject. Turn the focusing knob so that the white band reaches both distance figures. If necessary, extend depth by turning selecting wheel.

Releasing Shutter



Up to the moment of exposure all camera settings are kept under perfect control: sharpness, framing, exposure, shutter speed, and depth-of-field. They can be re-adjusted instantly if the subject so requires.

To unlock shutter release: move release guard from \downarrow (locked) to lower \updownarrow (unlocked) position.

Snapshot Exposure (1/500–1 sec.): press shutter release gently, selected speed goes off automatically.

Time Exposure ("B", over 1 sec.): press shutter release and hold for required time. Shutter will close when you let go.

Long Time Exposures ("B"): press release and lock with safety guard. Terminate exposure by releasing lock. (Caution: Do not shake camera! Shield the lens with your hand when opening and closing the shutter.)

Cable Release: insert in cable release socket with safety guard locked.

Film Transport and Shutter Tensioning

After each shot: swing out crank, turn it forward with one continuous swing, until it stops and then back again to stop.

The shutter is now automatically cocked. The crank will turn only after releasing shutter. Double exposures or blank frames are positively eliminated. If the crank can be turned, it must be turned – forward and back to lock. Only if it is locked the camera is ready to shoot. (Exception: double exposures, → page 25.)

The crank need not be folded down after each shot when shooting in rapid sequence.

When using the Rolleikin: the film transport for the 35 mm film is accomplished in exactly the same manner as above.

When using the Plate Adapter: turning the crank by one half turn will suffice to cock the shutter.

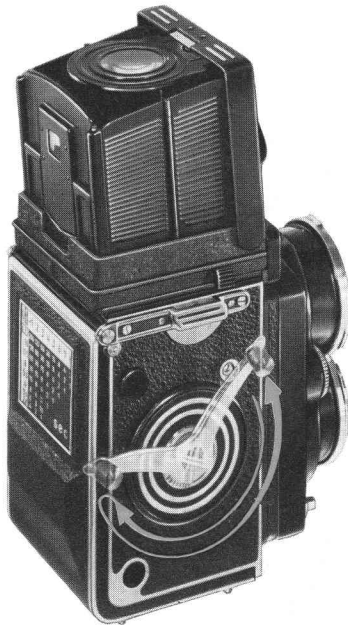

Unloading the Camera

After the twelfth exposure the film is finished: the crank is no longer locked and can be turned freely again.

To remove the film: roll up remaining backing paper with three full revolutions. Open back in subdued light. Pull out upper spool knob and remove film from the left. Fold backing paper (for convenient tearing when developing) and fasten down with sticker. Keep the exposed film away from light and return it to original packing.

To transfer the empty spool: pull out lower film spool knob and lift the now empty spool out of the lower spool chamber. Insert the spool into upper spool chamber, fitting the slotted end over the winding key on the right side.

Load the camera with a fresh roll of film avoiding direct sunlight. Use your own body's shadow for protection.

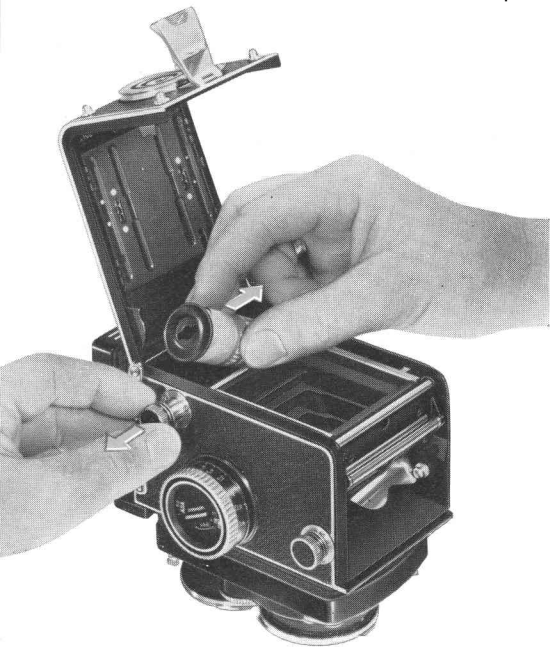

A Few Words about the Care of Your Camera

Your camera deserves careful handling – dependable performance will be your reward.

Sparkling cleanliness, especially of all the optical parts, is a pre-requisite for maximum sharpness. In cleaning all optical surfaces (lenses, focusing screen, reflex mirror, flat glass), use a camel's hair brush to remove dust, then wipe off fingerprints with a soft cloth or doeskin. On the contoured undersurface of the focusing screen, use a clean soft brush only; avoid touching the screen. To prevent a dust-attracting electrostatic charge, breathe onto the surfaces before and after cleaning and let moisture evaporate, do not wipe off. – Incidentally, the lenses have abrasion resistant anti-reflection coatings. The reflex mirror, too, is covered with a special protective layer to withstand scratches and corrosion. However, any cleaning should be done carefully and only when necessary.

Do not forget that moisture, dust, sand, strong sunlight, a hard blow or fall can be harmful to a precision camera. If possible, always use the eveready case. Carry camera around neck and when riding in your car, keep your camera in a safe spot, well protected against the hot sun and bumpy roads. In a nutshell: be kind to your Rolleiflex!

And please remember: Franke & Heidecke always maintain their interest in the welfare of your camera. The Service Departments at the factory and the factory representatives in foreign countries will always gladly take care of any special technical problems that might come up during your photographic practice.

Flash Shots



Modern flash technique permits taking snapshots even under lighting conditions which do not allow instantaneous exposures with a hand-held camera.

The Synchro-Compur shutter is fully synchronised for all electrically fired types of flash. It fires high-speed electronic flashes as well as the slower flash bulbs at exactly the right moment to permit the fastest shutter speeds in both cases with the appropriate synchronising setting.

Connecting the flash cord: insert the tip into the flash connector socket on the camera. – When disconnecting flash cord: swing locking lever at the socket downward and pull out tip.

Setting the contact to $\frac{1}{2}$ (X-contact) or Q (M-contact): pull out the small knurled knob and swing synchro lever to the desired position.



The X-setting (for normal use) utilises the full light output of the flash with the prescribed shutter speed and can also be used for shots with the self-timer. The M-setting is for flash bulbs only and synchronises the fastest speeds, up to the top speed.

Electronic flash:

Always use X-contact for all shutter speeds up to 1/500 th sec.



Flash bulbs:

X-contact when using 1/30 th sec. or slower shutter speeds



M-contact for speeds up to 1/500 th sec.
(according to type of flash bulb)

The correct exposure depends on the light output of the flash and the distance between flash and subject. Therefore, it cannot be determined with an exposure meter. Exact data regarding choice of proper contact, exposure time, and diaphragm may be gathered from the material furnished by the lamp manufacturers.

Flash Exposures

Uncouple the exposure value (→ page 13) and set the aperture and shutter speed separately, according to the instructions for the flash bulb or unit.

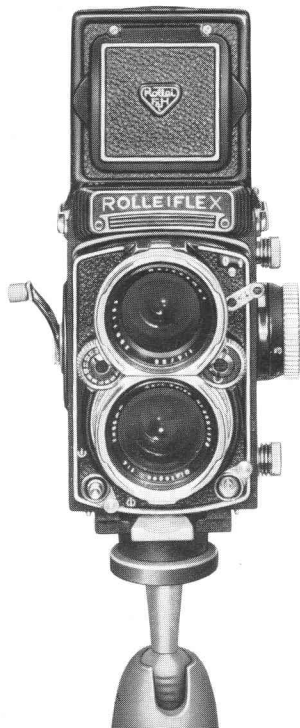

Exposures with Self-timer

If you photograph a group of people or take a remembrance snapshot and you also want to appear in the picture, cock the self-timer before releasing the shutter. When pressing the shutter release, the shutter will open for the previously selected exposure time after a delay of approximately 10 secs.

The self-timer can be used with all instantaneous speeds 1/500 – 1 sec. (red section of speed scale) and also for flash shots with the $\frac{1}{2}$ contact setting. It operates only when the shutter is cocked.

To operate self-timer: cock shutter (film transport), move self-timer tensioning lever V in the direction of the arrow until it stops. Release shutter as usual.

Shutter and self-timer may be left tensioned even when camera is not in use – spring strength will not deteriorate.

Tripod Pictures

Length of the tripod's screw must not exceed the normal 3/16" (4.5 mm) – if necessary, use a spacer of proper thickness. A reducing bushing is available for use with English thread (1/4"). More practical: Rolleiflex for instant mounting of camera to tripod.

Double Exposures At Will

For intentional multiple or trick exposures the double exposure prevention mechanism can be by-passed (possible only with roll-film loaded camera): after exposure move release ring at base of crank in direction of arrow and then turn crank through one complete backward revolution until it stops. This operation cocks the shutter for a second exposure without advancing the film. After releasing the shutter, repeated tensioning in the described manner for multiple exposures is possible. An absolutely firm tripod is a pre-requisite for this kind of work.

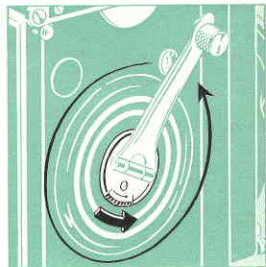

Exposure Values and Time Exposures

At exposure values below 8 the range of available instantaneous speeds decreases, so that at the B setting, time exposures become necessary. The exposure value table in the camera back indicates the possible aperture-time combinations for this purpose. The table thus gives the exposure time in seconds for a measured exposure value (top row) and any given aperture (left hand column). For example for exposure value 4 and aperture f/11, the time is 8 seconds.

At the B setting adjust the aperture by turning the aperture wheel with the central locking button depressed. The exposure value figures on the shutter speed wheel then no longer apply.

↓

	1	2	3	4	5	6	7	8
f: 22	250	125	60	30	15	8	4	2
16	125	60	30	15	8	4	2	1
11	60	30	15	8	4	2	1	
8	30	15	8	4	2	1		
5,6	15	8	4	2	1			
4	8	4	2	1				
3,5	6	3	1,5					
2,8	4	2	1					
								sec

The Exposure Meter, for subsequent installation

Detailed instructions for fitting are enclosed with every meter.

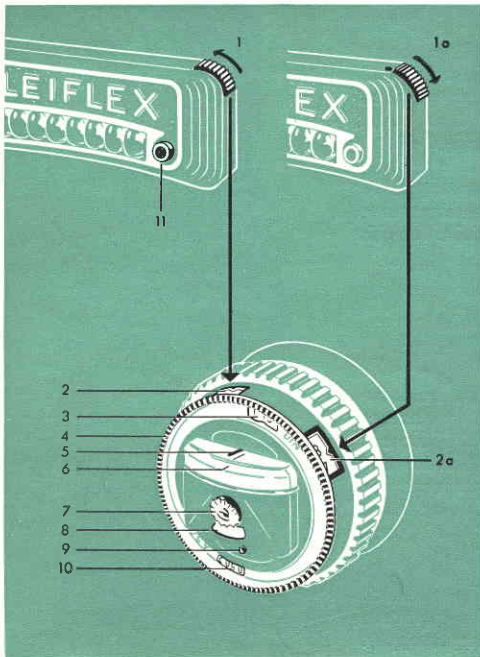

- 1 Control switch on nameplate: position 1 for normal light intensities, position 1 a – red dot visible – for weaker illumination.
- 2 Exposure value indication: use window 2 for switch position 1, window 2 a – edged in red – for switch position 1 a.
- 3 Setting window for DIN film speed ratings
- 4 Setting ring
- 5 Red setting pointer
- 6 Black indicator pointer
- 7 Adjustment of film type reminder
- 8 Film type indicator window
- 9 Lock screw to fasten meter in its bayonet socket
- 10 Setting window for ASA film speed ratings
- 11 Retaining knobs for diffuser

Measuring Exposure

Changing DIN / ASA film speed rating setting (necessary whenever a different film speed is used): turn adjusting ring 4 past the left or right click stop until the correct speed rating appears above the indicator mark.

To take reading: for reflected light measurement (→ page 28): point camera towards subject or towards most important detail in subject – check in ground glass.

For incident light measurement (→ page 29): snap diffuser into position, from above retaining knobs 11, over the photo cell. Turn camera around so that the photo cell faces the same direction towards the light as the subject.

Measuring exposure value: turn adjusting ring 4 until the red pointer covers the black indicating pointer – read the exposure value in the appropriate window 2 (red-edged window 2 a, when red dot is visible at the switch – 1 a). If the red pointer does not reach the black, change to higher sensitivity position with switch (1, 1 a).

The shock mounted exposure meter is ruggedly built and will withstand the strongest light for any length of time, in either switch position. It is not necessary, therefore, to cover the photo cell when not in use.

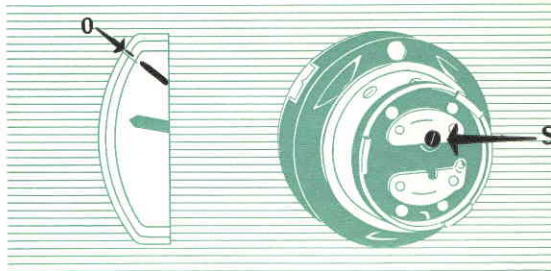

Checking and adjusting the meter

When the photo cell is completely covered, the black pointer should be in zero position, pointing to the short green line. If it is off this position, perhaps due to prolonged and heavy shaking, turn safety screw 9 until it stops. Turn meter towards the left to disengage from bayonet socket and remove. Adjust screw S on back of instrument until black indicator needle points to outer green reference mark. Re-insert instrument, lock into position and tighten safety screw.

Reflected light or object measurement

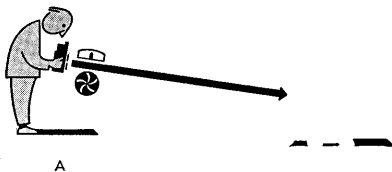

The quick and convenient method especially suited to the Rolleiflex: aim at the subject (A). Measuring in this position covers the entire picture area, as seen on the ground glass screen. Meter reading, exposure value and focusing image can simultaneously be checked with camera in shooting position. Changes in light intensity can be observed instantly, even up to shooting time.

Using the reflected light method, a reading for the average brightness of the entire subject area is obtained. Application: evenly lighted subjects, for front or side lighting without heavy shadows in

picture (standard lighting for color) and also for high contrast subjects when the light and shade areas are evenly apportioned throughout the picture.

In special cases, **detail measurement** becomes very helpful: when either very light or very dark areas prevail, take individual readings of light and shade areas and use a mid-point value. The ground glass control image facilitates accurate measurement; it permits concentrating — by altering camera position — on most important elements of the picture or even to choose a nearby substitute object of the same brightness for reading.

Incident light measurement

(with diffusor)

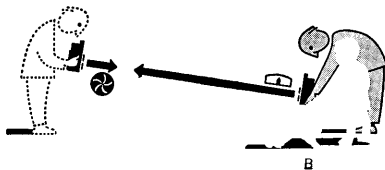

Instead of measuring the light reflected **by** the subject, this method measures the light as it falls **on** the subject. This is accomplished by attaching the diffusor over the photo-cell, to serve as a surface receiving the same illumination as the subject, and pointing the exposure meter in the opposite direction (B).

To get correct reading, aim from subject to intended camera position. In the open, when subject cannot be approached, aim the photo cell, turned around of course, along a line drawn from center of scene to camera. An exposure value of average scene

brightness will result. When the important part of the scene is lighter or darker than the average, the measured exposure value should be corrected (usually 1/2 EV is sufficient). Position of the sun, special effect lighting, strong side or back lighting will have no influence on the proper reading and are disregarded. Detail measurements are not necessary, either.

Main uses: against-the-sun shots, strong backlighting, in shade with strong rays of sunshine, for objects with brilliant backgrounds (sky, snow, water, beach) for small objects as in Rolleinar shots.

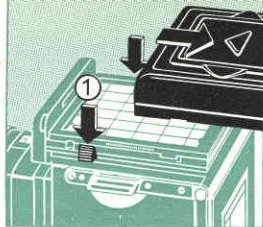

Inserting the Rolleikin Focusing Screen Mask:

To remove the hood: press the spring catches on either side of the hood and slide hood towards rear ①. – To replace: press hood down on track and slide forward until it locks.

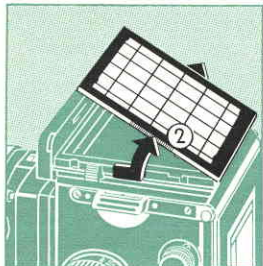

To lift the focusing screen: take hold of the two sides of the frame, pull backwards slightly and lift ②. – Close by pushing downward.

Inserting the focusing screen mask: drop into place so that the notch and punched holes fit over the studs provided ③. The Rolleikin mask is now coupled to the automatic parallax correction of the camera.

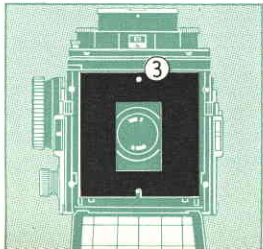

Adjusting the film pressure plate (→ page 8): slide plate downward until inscription $1 \times 1\frac{1}{2}$ " (24 x 36 mm) is visible.

Adjusting the eveready case to the larger diameter of the Rolleikin counter knob: remove leather insert at the left side after bending the metal retaining clips upward.

For more detailed information, please refer to the Rolleikin instruction sheet.

Changing the Magnifier for Eyesight Correction

For focusing without spectacles the magnifier can be changed to cover spectacle prescriptions from + 3 to - 3 dioptres. You can do that yourself as follows:

Swing up the magnifier. Press the edge of the lens forward with a finger nail ④, and lift out. To fit the lens, press it forward against the retaining spring and let it snap into place in the mount.

Changing the rear magnifier (Tele-Rolleiflex): remove and open focusing hood. Use both thumbs to grasp, from the inside of the rear wall, the two retaining clips on either side of the rear peep window and pull back retaining lever ⑤. After changing magnifier, push retaining spring forward until it snaps into place.

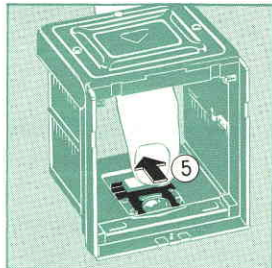
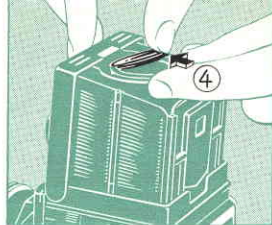

Exchanging the Back

(to use the plate adapter)

To exchange camera back: open back fully, turn the safety latch below the right back hinge in the same direction ⑥ and remove back. To attach: with the safety latch in upper position, insert back first into the left, then into the right back hinge and close.

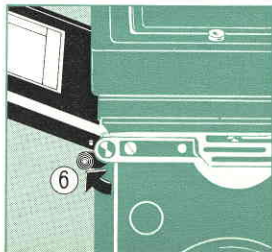

The Practical Accessories

Protecting the Camera

- Eveready Case with compartment for optically flat glass
- Protective Cap for exposure meter (leather), for attaching to eveready case
- Protective Cap for exposure meter (plastic), for attaching to neck strap
- Neck Strap
- Shoulder Pad for neck strap
- Lens Cap, chromium-plated

Measuring Exposure

- Light Meter Elements for installation

For Focusing control in eye-level

- Rollei Penta Prism
- Penta B, special eyepiece for Penta Prism

The Optical Accessories

- For Wide-angle Rolleiflex:
bayonet size IV,
- for Tele Rolleiflex:
bayonet size III
- Lens Hood**

Supplementary Lens Sets with parallax correction

- for Wide-angle Rolleiflex:
Rolleinar 2 for close-ups
from 1'8" to 9½"

for Tele Rolleiflex:

- ✓ Rolleinar 0,35 in hinged twin mounts,
focusing range 9'2" - 4'5"
- ✓ Rolleinar 0,7 in twin mounts,
focusing range 4'6½" - 3'½"
- ✓ Rolleinar 1 for close-ups
from 3'3½" to 2'4¾"
- Rolleinar 2 for close-ups
from 1'8½" to 1'6"
- ✓ Rolleinar 3 for close-ups
from 1'2¼" to 1'1"

Rollei Filters

Filter Compensating
Number

For black-and-white films (pan emulsions)

Light yellow	- 1
Medium yellow	- 1.5
Light green	- 1
Green	- 1.5
Orange	- 1.5 to - 3
Light red	- 2 to - 3.5
Light blue	- 0.5
Ultra violet	- 0.5

For Color Films**Rollei Color Conversion Filters:**

R 1	} to correct for excessive blue	0
R 2		-0.5
R 5		-0.5
R 11		-1

B 1	} to correct for excessive red	0
B 2		-0.5
B 5		-1
B 11		-1.5

For General Use:

Rolleipol, Polarizing Screen -1.5

For infrared emulsions

Infrared Filter

Diffusion Discs

for Tele Rolleiflex:

Rolleisoft 0

Rolleisoft 1

Flash Attachment

Rolleiflash 2 Attachment
with 1 feet cord and bracket

Bracket

Rolleiflash comb 2, supplementary flash
unit, with 10 feet cord

Carrying Case for Rolleiflash or
Rolleiflash comb

10 Feet Cord for Rolleiflash

32" Cord for Rolleiflash

Coiled Cord 1'3' for Rolleiflash

Connector for 2 cords

Rollei Adapter Outfits**For Cut-film and Plates 2½ × 3½":**

Plate adapter outfit 2¼ × 2¼" (1 adapter
back, 3 slides, 3 cut film sheaths)

Adapter Back

Slide

Cut-film Sheath

Leather Case for 2 Slides

Focusing Screen Slide

For Rollfilm with Flat Glass:

Spare Optically Flat Glass Plate

For 35 mm. Film:

Rolleikin 2.8 (35 mm. attachment)

Direct View Finder Mask for Tele Rolleiflex
with Rolleikin

For Mounting the Camera

Rolleifix Tripod Head for quick fastening

Rollei Pistol Grip with Rolleifix tripod head

Wrist Loop for Pistol Grip

Panorama Head for Tele Rolleiflex

Technical specifications subject to change without notice.

Rolleinar Focusing Ranges (measured from lens panel to subject)

Rolleinars (single or combined)	Focusing Range		With full lens extension	
	from (in.)	to (in.)	Reproduction ratio approx.	Subject area covered (in.)
Wide-angle Rolleiflex				
2	1'8"	9½"	1 : 4,2	9¾" × 9¾"
Tele Rolleiflex				
0,35	9'2"	4'5"	1 : 8,6	1'6¼" × 1'6¼"
0,7	4'6½"	3'½"	1 : 5,9	1'½" × 1'½"
1	3'3½"	2'4¾"	1 : 4,8	10¼" × 10¼"
0,35 + 1	2'6¼"	2'½"	1 : 3,8	8⅞" × 8⅞"
0,7 + 1	2'½"	1'8½"	1 : 3,2	6¾" × 6¾"
2	1'8½"	1'6"	1 : 2,7	5¾" × 5¾"
0,35 + 2	1'6"	1'3¾"	1 : 2,3	4⅞" × 4⅞"
0,7 + 2	1'3¾"	1'2¼"	1 : 2	4⅜" × 4⅜"
3	1'2¼"	1'1"	1 : 1,8	3 ¹³ / ₁₆ " × 3 ¹³ / ₁₆ "
0,35 + 3	1'1"	11¼"	1 : 1,65	3 ⁹ / ₁₆ " × 3 ⁹ / ₁₆ "
0,7 + 3	11¾"	11"	1 : 1,55	3 ⁵ / ₁₆ " × 3 ⁵ / ₁₆ "